

Thumb Machine Screws

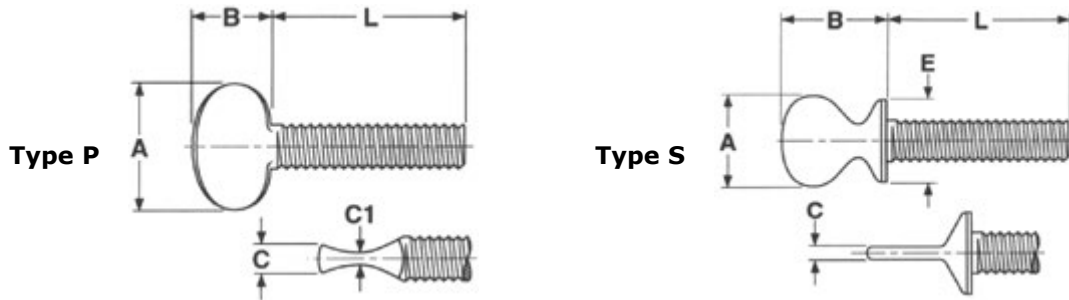

Thumb Screw no Shoulder, Type P Zinc = T020-----Z1

Thumb Screw with Shoulder, Type S Zinc = TS020-----Z1

Type P

Nominal Size	Thread Pitch	A		B		C		C1		L	
		Head Width		Head Height		Head Thickness		Head Thickness		Practical Screw Lengths	
		Max	Min	Max	Min	Max	Min	Max	Min	Max	Min
8	32	0.51	0.49	0.32	0.30	0.09	0.07	0.04	0.02	1.00	0.38
10	24	0.89	0.83	0.78	0.66	0.18	0.16	0.08	0.06	2.00	0.50
¼	20	1.05	0.99	0.94	0.81	0.24	0.22	0.10	0.08	3.00	0.50
5/16	18	1.21	1.15	1.00	0.88	0.27	0.25	0.11	0.09	4.00	0.50

Type S

¼	20	0.55	0.52	0.64	0.61	0.07	0.05	0.47	0.44	1.50	0.50
---	----	------	------	------	------	------	------	------	------	------	------

Wing Machine Screws

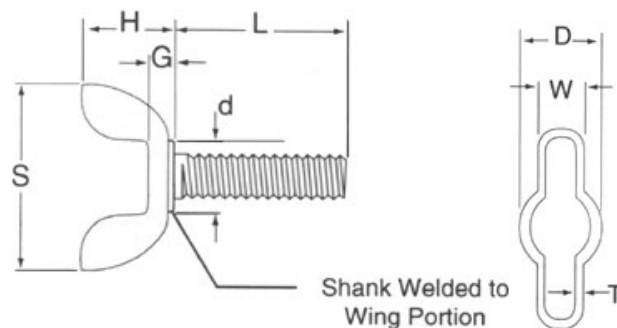

Wing Screw

Zinc = MW020-----Z1

Nominal Size	Thread Pitch	S		H		W		D		T		L	
		Wing Spread		Wing Height		Wing Thickness		Shank Diameter		Stock Thickness		Practical Screw Lengths	
		Max	Min	Max	Min	Max	Min	Max	Min	Max	Min	Max	Min
8	32	0.78	0.72	0.40	0.34	0.18	0.12	0.40	0.34	0.04	0.03	0.75	0.38
10	24	0.90	0.84	0.46	0.40	0.21	0.15	0.53	0.47	0.04	0.03	1.00	0.38
¼	20	1.09	1.03	0.46	0.40	0.26	0.20	0.61	0.55	0.04	0.03	1.50	0.50
5/16	18	1.31	1.25	0.62	0.56	0.29	0.23	0.68	0.62	0.07	0.05	1.50	0.50